

Stainless Steel Indirect Water Heaters

Every KNIGHT needs Stainless Steel

How It Works



The SQUIRE indirect water heater works in service to the KNIGHT, providing a continuous supply of domestic hot water. The dependable stainless steel tank and heating coil offer a recovery rate up to three times faster than

conventional gas or electric water heaters. And when in the service of the 98% efficient KNIGHT Heating Boiler, less fuel is consumed for lower energy bills.



Five Models – From 30 to 120 gallons

- High Recovery
- Built-In, Pre-Wired Thermostat
- Dent Resistant Jacketing
- 316L Passivated Stainless Steel Construction
- Large Heat Exchanger
- Ultra Light Weight
- 150 psi Working Pressure Tank
- 150 psi Working Pressure Coil



Standard Features

- 316L Passivated Stainless Steel Tank
- High Capacity Single Wall Stainless Steel Heating Coil
- Adjustable Thermostat
- Built-in Thermometer
- Recirculation Loop Connection
- 1" Boiler Supply and Return Connections
- 1" Domestic Water Connections
- Non-CFC Foam Insulation
- Removable Corrosion Resistant Outer Jacket
- Temperature and Pressure Relief Valve Opening
- Warranty - *Limited Lifetime*

Five year warranty on Commercial.

One year warranty on parts.

(See warranty for details)

And since the KNIGHT is standard with Domestic Hot Water Prioritization, the KNIGHT and SQUIRE are ready to go into battle, right out of the box!

Heat Exchanger Pressure Drop

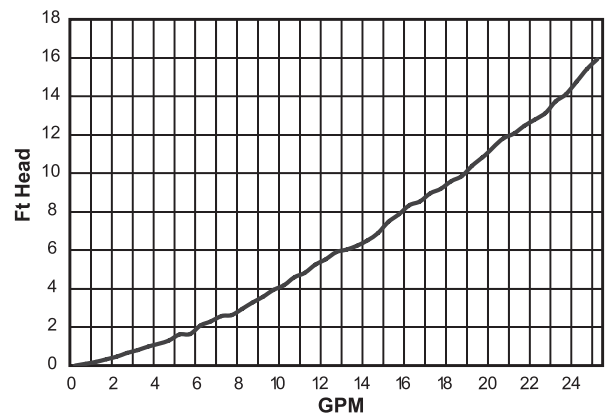

Stainless Steel Indirect Dimensions and Specifications

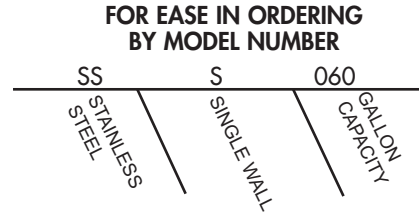
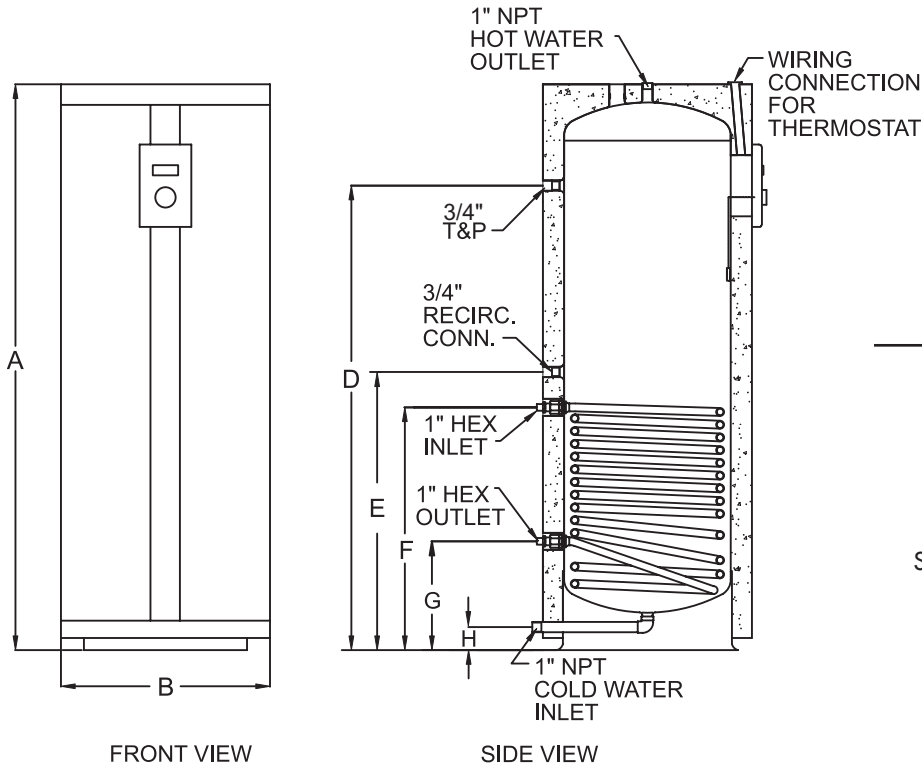

This heater is a 60 gallon, single wall coil, Stainless Steel indirect water heater.

Model	Gal. Cap.	1st Hour Rating @ 140°F	1st Hour Rating @ 115°F	A	B	D	E	F	G	H	Shipping Weight
SSS030	32	142	189	37-1/2"	23-1/4"	27-3/4"	22-3/4"	19"	12-1/4"	2-3/4"	110
SSS040	42	150	195	47-1/4"	23-1/4"	41"	24-1/2"	20-1/2"	12-1/4"	2-3/4"	135
SSS060	60	273	360	63"	23-1/4"	56-3/4"	31"	27"	12-1/4"	2-3/4"	155
SSS085	90	501	667	66-1/4"	27-1/4"	59-1/4"	39-3/4"	36-1/2"	13-1/2"	3-1/2"	245
SSS120	119	529	695	82-1/4"	27-1/4"	75"	39-3/4"	36-1/2"	13-1/2"	3-1/2"	285

Notes: Water connections are 1" NPT
 Heat Exchanger connections are 1" female NPT
 Performance data is based on manufacturer's test results.
 All ratings are based on 180°F boiler water temperature, 50°F potable water temperature and an approximate boiler output of 220,000 Btu/Hr.

Certified for Potable Water and Space Heating Applications

This water heater is suitable for water heating and space heating. Toxic chemicals, such as those used for boiler water treatment shall NEVER be introduced into the potable water system. This water heater may NEVER be connected to any existing heating system or components previously used with non-potable water heating appliances.

All models available with a Lifetime Limited Warranty Against Tank Failure. All parts are warranted for one year. Five year limited warranty on all models when installed in a commercial application.



Lochinvar Corporation • 300 Maddox Simpson Pkwy • Lebanon, TN 37090 • 615-889-8900 / Fax: 615-547-1000

www.Lochinvar.com